



FULL SCALE ARENA
ISO TEST REPORT

Rendered to:

Solar Gard®

MODEL DESIGNATION: Solar Gard® Armorcoat® Safety & Security Films

PRODUCT TYPE: Safety and Security Films

This report contains in its entirety:

Cover Page: 1 page
Report Body: 12pages
Appendix A: 12 pages
Appendix B: 2 pages
Appendix C: 9 pages
Appendix D: 4 pages
Revision Log: 1 page

Test Report No.: F5228.01-801-12

Test Dates: 05/12/16 and
05/13/16

Report Date: 05/26/16

Test Report Retention End Date: 05/26/20

Solar Gard®
Solar Gard® Armorcoat® Safety & Security Films

1.0 MANUFACTURER'S IDENTIFICATION

- 1.1 Name of Applicant: Saint-Gobain Solar Gard
4540 Viewridge Avenue
San Diego, CA 92123
Voice: 800-359-8468
- 1.2 Contact Person: Miguel Detres

2.0 SCOPE OF WORK

- 2.1 Introduction
Solar Gard retained Architectural Testing, Inc. (ATI) to conduct a full scale arena blast test on their Solar Gard Armorcoat window film per the requirements of ISO 16933:2007.

3.0 PRODUCT IDENTIFICATION

- 3.1 Product Type: Safety & Security Film
- 3.2 Model Designation: Solar Gard Armorcoat
- 3.3 Performance Class: 124 ft Standoff: exceeds 7.25 psi - 36 psi-msec
(37.79 m Standoff: exceeds 50 kPa – 250 kPa-msec)
- 3.4 Overall Size: Specimens 1-12: 36-1/2" (w) x 40-3/4 (h)
(927 mm (w) x 1137 mm (h))
- 3.5 Location: Lynn County, Texas
- 3.6 Elevation: 3126 ft. (952.8 m)
- 3.7 Test Dates: 05/12/2016 and 05/13/2016
- 3.8 Test Times: 5:30 p.m. and 2:00 p.m.
- 3.9 Ambient Temperatures: 80° F (26.67° C) and 83° F (28.33° C)
- 3.10 Relative Humidity's: 51% and 38%
- 3.11 Weather Conditions: Windy
- 3.12 Configuration: Fixed
- 3.13 Drawing: This test report is incomplete if not accompanied by Solar Gard drawing labeled "Test Specimen Drawings" (sheets 1 through 12) bearing the digital stamp of Architectural Testing, Inc.
- 3.14 Sample Source: Specimens provided by Solar Gard.

4.0 EXPLOSIVE CHARGE

- 4.1 Charge Type: ANFO(Ammonium Nitrate Fuel Oil)
- 4.2 Charge Weights: 425 lbs (192.777 kg) and 400 lbs (181.43 kg)
- 4.3 Standoff Distances: 124 feet (37.79 m)

5.0 BLAST REACTION CHAMBER

The blast reaction chamber construction consists of wide flange steel beams, steel tubes, and steel skin that enclose the chambers. ATI also placed four (4) foot (1219 mm) wide wing walls on the blast reaction chamber top and sides to reduce clearing effects on the reflecting surface. The overall dimensions of the blast reaction chamber are twenty-eight (28) feet (8534 mm) wide, sixteen (16) feet (4876 mm) tall, and ten (10) feet (3048 mm) deep. The blast reaction chamber encloses a volume that houses witness panels and structural members. The sealed surfaces of the blast reaction chamber prevent air blast pressure from wrapping around the test specimen so that the blast pressure loads only one side of the test specimen.

6.0 PRODUCT DESCRIPTION

6.1 Frame Construction

The frame was fabricated using the aluminum extrusions defined in Tables 1 and 2.

Table 1: Aluminum Extrusion Details- Insulated Glass Unit YKK YES 45 FI

Description	Manufactured Part #	Overall Dimensions	Material
Head	E9-1013	4.5" x 2" x 0.094" (114 mm x 50.8 mm x 2.4 mm)	6063 T5 Aluminum
Jamb	E9-1013	4.5" x 2" x 0.094" (114 mm x 50.8 mm x 2.4 mm)	
Sill	E9-1089	4.5" x 2" x 0.071" (114 mm x 50.8 mm x 1.8 mm)	
Glazing Stop	E9-1015	1.3" x 1.3" x 0.055" (33 mm x 33 mm x 1.40 mm)	
Fastener	PC-1216 #12	1" (25.4 mm)	CRS
Gasket (vinyl filler)	E2-0052	-	EPDM

Table 2: Aluminum Extrusion Details- Single Lite Unit YKK YES 45 FS

Description	Manufactured Part #	Overall Dimensions	Material
Head	E9-1003	4.5" x 1.75" x 0.094" (114 mm x 44.5 mm x 2.4 mm)	6063 T5 Aluminum
Jamb	E9-1003	4.5" x 1.75" x 0.094" (114 mm x 44.4 mm x 2.4 mm)	
Sill	E9-1069	4.5" x 1.75" x 0.071" (114 mm x 44.4 mm x 1.8 mm)	
Glazing Stop	E9-1005	1.92" x 1.06" x 0.055" (48.8 mm x 26.7mm x 1.4mm)	
Fastener	PC-1216 #12	1" (25.4 mm)	CRS
Gasket (vinyl filler)	E2-0052	-	EPDM

6.1.1 Corner Construction

The frames were all square cut and assembled using fastener PC-1216 #12 (1" (25.4 mm)).

6.1.2 Glass Bite

Each window unit had a glass bite of 3/8 inch.

6.2 Glazing Details

6.2.1 Glazing Dimensions

- 6.2.1.1 Daylight opening of 32 ½" by 40 ¾" (825 mm by 1035 mm)
- 6.2.1.2 Overall unit 36 ½" by 44 ¾" (927 mm by 1137 mm)

6.2.2 Glazing constructions & attachment system description (illustrated in Appendix A)

6.2.2.1 Specimen 1 (3 units) - Insulated glass unit

- 6.2.2.1.1 ¼" (6 mm) annealed glass + ½" (12.7 mm) air + ¼" (6 mm) annealed glass
- 6.2.2.1.2 Anchored with EdgPro™ flexible mechanical attachment system

6.2.2.2 Specimen 2 (3 units) - Insulated glass unit

- 6.2.2.2.1 ¼" (6 mm) annealed glass + ½" (12.7 mm) air + ¼" (6 mm) annealed glass
- 6.2.2.2.2 Anchored with EdgPro™ aluminum mechanical attachment system on four sides

6.2.2.3 Specimen 3 (3 units) – Single glazed unit

- 6.2.2.3.1 ¼" (6 mm) tempered glass
- 6.2.2.3.2 Anchored with EdgPro™ flexible mechanical attachment system

6.2.2.4 Specimen 4 (3 units) – Single glazed unit

- 6.2.2.4.1 ¼" (6 mm) tempered glass
- 6.2.2.4.2 Anchored with Sikasil® SG20 structural sealant. The wet glaze attachment consisted of a ½" (12 mm) bead on the interior side of the glazing to adhere the film to the window frame as shown in Section II. Specifications for the Sikasil® SG20 can be reviewed in Appendix D.

6.2.3 Safety & Security Film

Each specimen used the safety film Solar Gard® Armorcoat® 8mil.

7.0 PRODUCT INSTALLATION

7.1 Table 3 provides details of the product installation into the steel opening.

Table 3: Product Installation Details

Fastener Schedule	Fastener Description
4-1/2" (114 mm) from ends and 10" (254 mm) on center thereafter	Two (2) 1-1/2" x 1-1/2" (38.1 mm x 38.1 mm) angles were welded together using two (2) 1/4" (6.35 mm) fillet welds and used to sandwich the frame on either side. The exterior angles were mechanically fastened to the steel opening using one (1) 3/8" x 1-1/2" (9.53 mm x 38.1 mm) HH Gr. 5 Bolt and the interior angles were welded to the steel opening using two (2) 1/4" (6.35 mm) fillet welds– Details in Section III
4-1/2" (114 mm) from the Top and Bottom	2" (50.8 mm) clips on the verticals of the angle – Details in Section III

8.0 INSTRUMENTATION

8.1 Data Acquisition System

ATI used a high speed data acquisition system with a system record time of one-hundred thousand (100,000) samples per second.

8.2 Reflected Pressure Transducers

ATI placed three (3) reflected pressure transducers on each single span blast reaction chamber to measure the reflected blast pressure time histories acting on the surface of the mock-up. The reflected pressure transducer locations are given in Figures 1.

8.3 Free Field Pressure Transducers

ATI used one (1) free field pressure transducer to measure the free field incident air blast pressure time histories. ATI placed this transducer further than 25 feet (7.620 m) from any of the blast reaction chambers at a standoff distance of 124 feet (37.79 m).

8.4 High Speed Cameras

ATI used digital high speed cameras to record system response under air blast pressure. One (1) camera filmed the exterior of the mock-up and one (1) camera filmed the interior of each of the mock-ups during air blast pressure loading.

8.5 Witness Panels

ATI used witness panels defined in ISO 16933:2007 Section 6.6. The witness panel makeup consisted of two layers of material. The outer layer consisted of one-half (1/2) inch (12.70 mm) thick rigid foam plastic thermal insulation board composed of polyisocyanurate foam bonded to a durable white-matte non-glare aluminum facer and a reflective reinforced aluminum facer with a density of two (2) pounds per cubic foot (32.03 kilograms per cubic meter). The inside layer consisted of one (1) inch extruded polystyrene insulation with a density of 1.8 pounds per cubic foot (28.83 kilograms per cubic meter).

9.0 BLAST PRESSURE DATA AT 124 FEET STANDOFF

9.1 Reflected Pressure Transducer Location

Figure 1 shows the locations of the reflected pressure transducers on the three (3) single span reaction chambers.

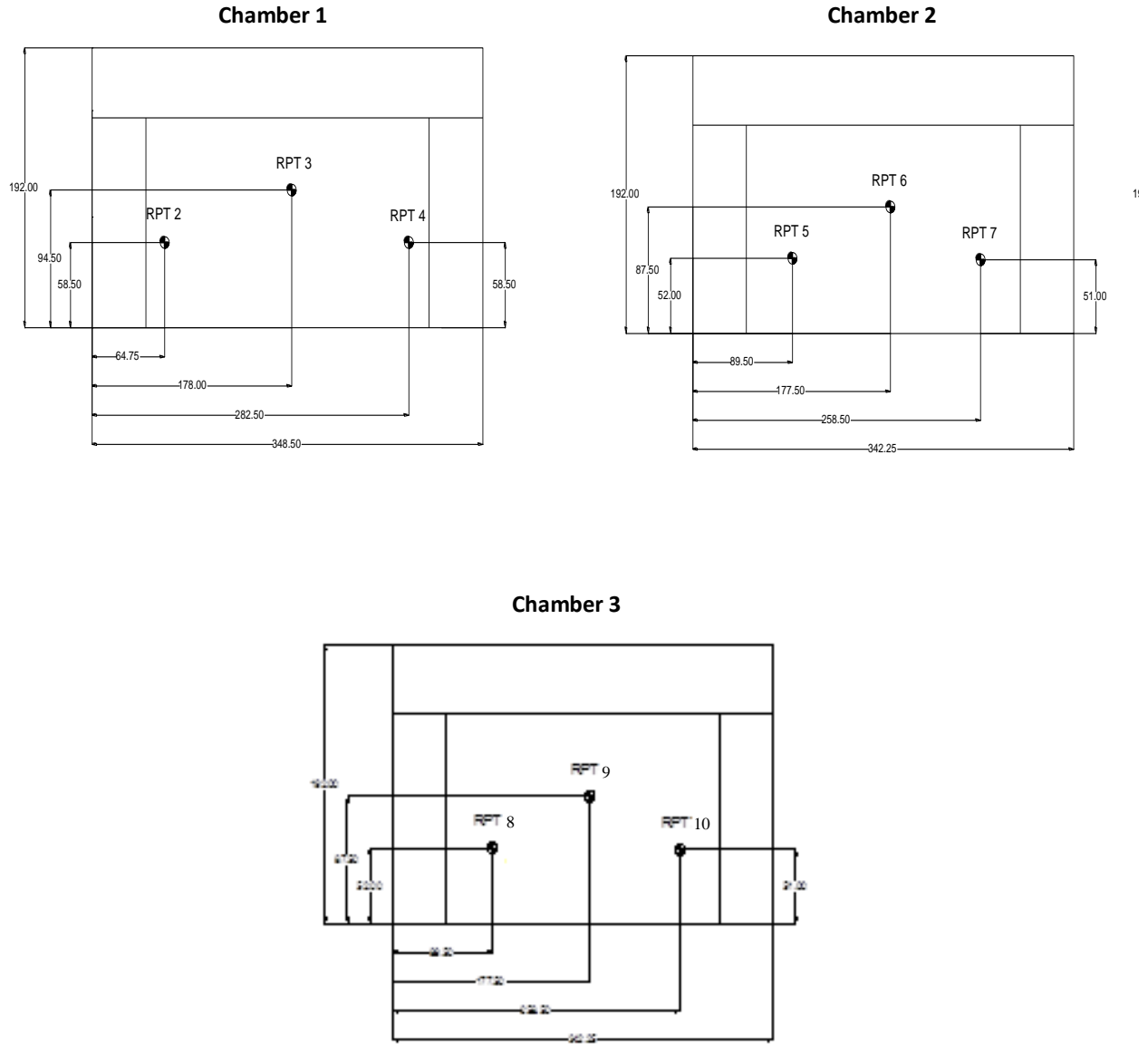

Figure 1: Reflected Pressure Transducer Locations

9.2 Reflected Air Blast Pressure Results

Tables 4 through 6 summarize the reflected blast pressure and positive phase impulse for each pressure transducer location. Figures 2 through 10 provide the reflected air blast pressure (red) and impulse (blue) time histories graphically.

Table 4: Reflected Air Blast Pressure Results Chamber 1

Air Blast Parameter	RPT 2	RPT 3	RPT 4	Average
Peak Pressure, psi (kPa)	8.21 (56.61)	8.05 (55.50)	8.24 (56.81)	8.17 (56.33)
Positive Phase Impulse, psi-msec (kPa-msec)	37.51 (258.62)	44.92 (309.71)	43.90 (302.68)	42.11 (290.34)
Positive Phase Duration (msec)	11.85	12.60	11.30	11.92

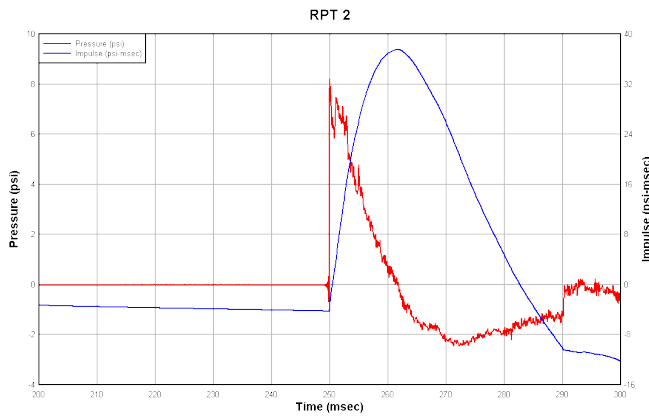

Figure 2: Reflected Air Blast Pressure (RPT #2)

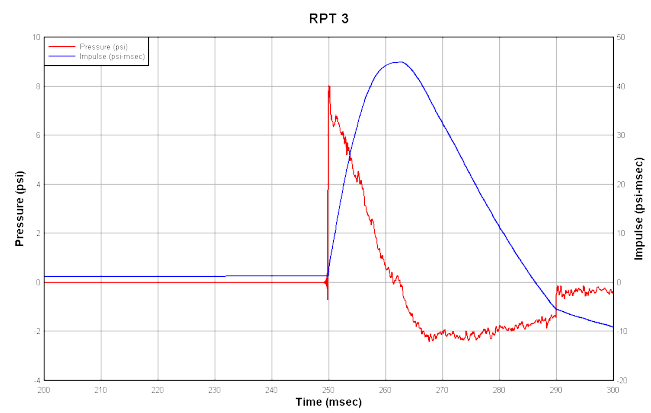

Figure 3: Reflected Air Blast Pressure (RPT #3)

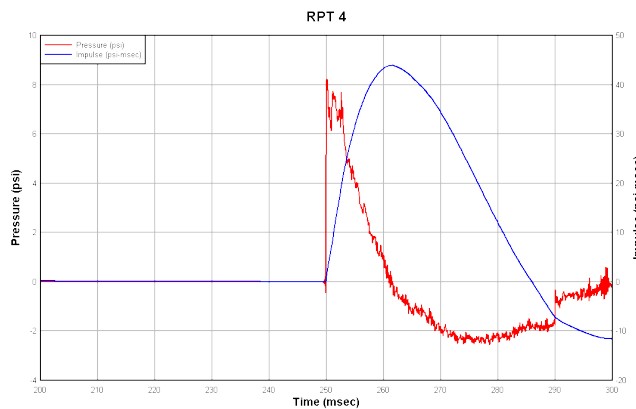

Figure 4: Reflected Air Blast Pressure (RPT #4)

Table 5: Reflected Air Blast Pressure Results Chamber 2

Air Blast Parameter	RPT 5	RPT 6	RPT 7	Average
Peak Pressure, psi (kPa)	8.45	8.59	8.37	8.47

	(58.26)	(59.23)	(57.71)	(58.40)
Positive Phase Impulse, psi-msec (kPa-msec)	39.51 (272.41)	45.47 (313.50)	43.94 (302.96)	42.97 (296.27)
Positive Phase Duration (msec)	11.00	12.55	11.25	34.8

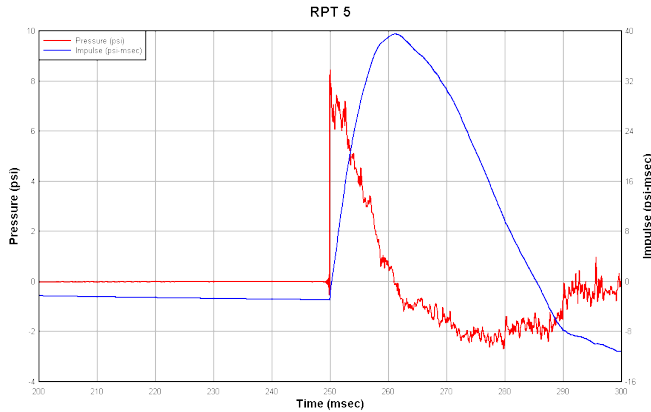

Figure 5: Reflected Air Blast Pressure (RPT #5)

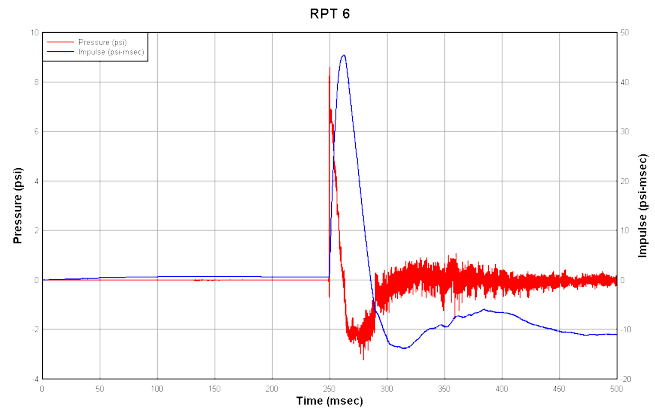

Figure 6: Reflected Air Blast Pressure (RPT #6)

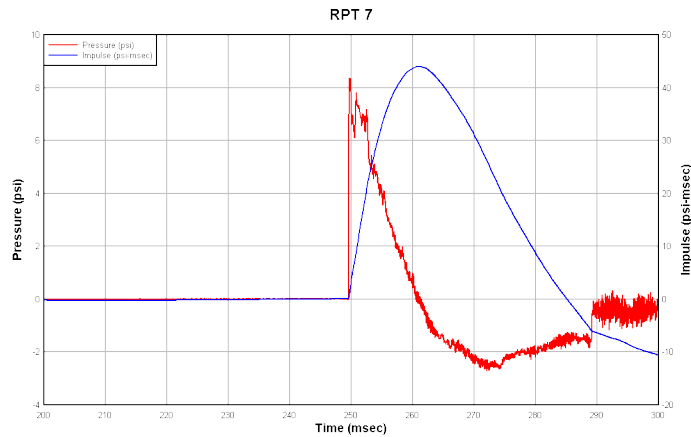

Figure 7: Reflected Air Blast Pressure (RPT #7)

Table 6: Reflected Air Blast Pressure Results Chamber 3

Air Blast Parameter	RPT 8	RPT 9	RPT 10	Average
Peak Pressure, psi (kPa)	7.75 (53.43)	7.82 (53.92)	7.22 (49.78)	7.60 (52.40)
Positive Phase Impulse, psi-msec (kPa-msec)	36.18 (249.45)	39.03 (269.10)	32.23 (222.22)	35.81 (246.90)
Positive Phase Duration (msec)	11.20	12.35	11.15	11.57

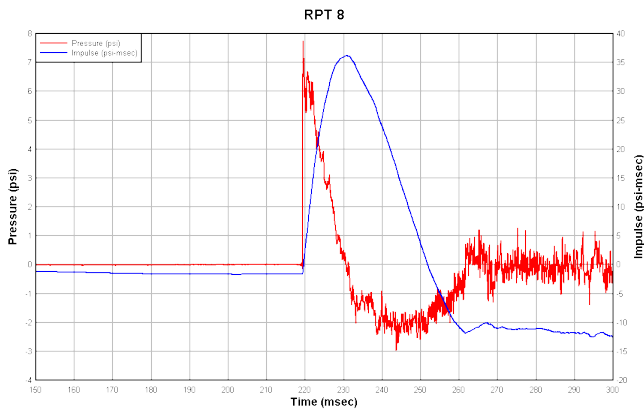

Figure 8: Reflected Air Blast Pressure (RPT #8)

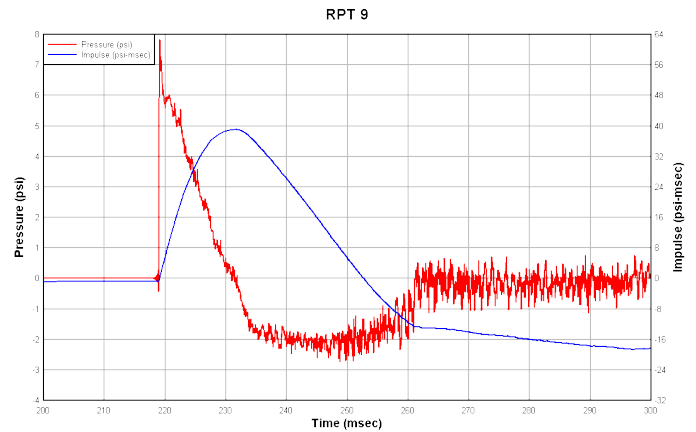

Figure 9: Reflected Air Blast Pressure (RPT #9)

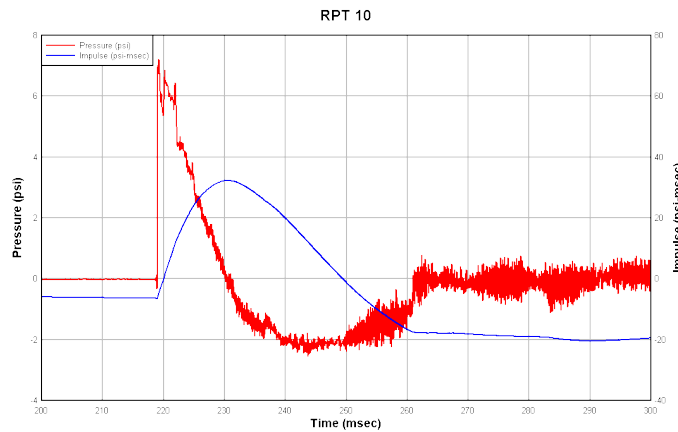

Figure 10: Reflected Air Blast Pressure (RPT #10)

9.3 Free Field Incident Air Blast Pressure Results

Table 7 and 8 provide the results obtained from the free field pressure transducers, and Figure 8 and 9 provides the free field incident air blast pressure time histories.

Table 7: Free Field Air Blast Pressure Results, Blast 1 Chamber 1

Blast Parameter	FF 1
Peak Air Blast Pressure, psi (kPa)	16.83 (116.04)
Peak Positive Phase Impulse, psi-msec (kPa-msec)	114.32 (788.21)

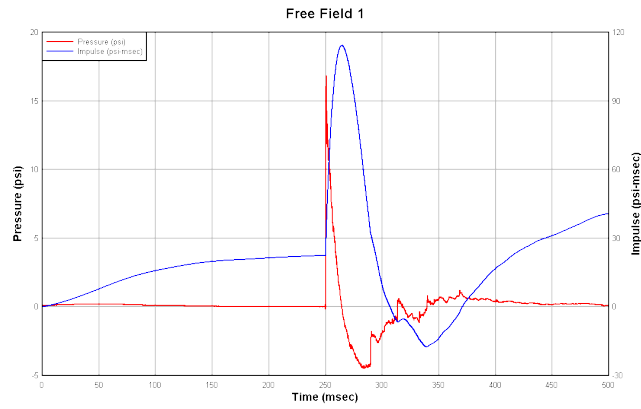

Figure 11: Free Field Incident Air Blast Pressure Time Histories

Table 8: Free Field Air Blast Pressure Results Chamber 3

Blast Parameter	FF 1
Peak Air Blast Pressure, psi (kPa)	10.64 (73.36)
Peak Positive Phase Impulse, psi-msec (kPa-msec)	74.48 (515.73)

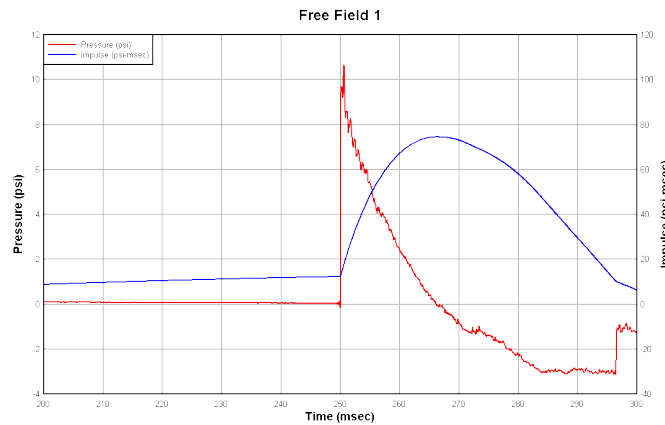

Figure 12: Free Field Incident Air Blast Pressure Time Histories

10.0 TEST RESULTS

10.1 Chamber 1

10.1.1 Glazing Response

Zero (0) perforations or fragment indents were observed anywhere in the vertical witness panel. Table 9 provides a summary of the glazing response during air blast pressure loading.

Table 9: Glazing Response Summary

Specimen	Fracture Status		Comments
	Inboard	Outboard	
1-1	Yes	Yes	Both interior and exterior lites fractured with full perimeter pullout to the exterior.
1-2	Yes	Yes	Both interior and exterior lites fractured with full perimeter pullout to the exterior.
1-3	Yes	Yes	Both interior and exterior lites fractured allowing fragments to enter the chamber up to 9-ft., IG spacer still retained in frame.
2-1	Yes	Yes	Both interior and exterior lites fractured but remained in opening. Exterior top stop came off but no penetrations.

10.1.2 Frame Response

The frame was undamaged.

10.2 Chamber 2

10.2.1 Glazing Response

Zero (0) perforations or fragment indents were observed anywhere in the vertical witness panel. Table 10 provides a summary of the glazing response during air blast pressure loading.

Table 10: Glazing Response Summary

Specimen	Fracture Status		Comments
	Inboard	Outboard	
2-2	Yes	Yes	Both interior and exterior lites fractured but remained in the opening, no ruptures or pullout.
2-3	Yes	Yes	Both interior and exterior lites fractured but retained in opening. Full length rip horizontally across the center, 27-in. Exterior top stop came off but no penetrations..
3-1	NA	Yes	Lite fractured with full perimeter pullout to the exterior. Exterior top stop came off but no penetrations.
3-2	NA	Yes	Lite fractured with full perimeter pullout to the exterior. Exterior top stop came off but no penetrations.

10.2.2 Frame Response

The frame was undamaged.

10.3 Chamber 3

10.3.1 Glazing Response

Zero (0) perforations or fragment indents were observed anywhere in the vertical witness panel. Table 11 provides a summary of the glazing response during air blast pressure loading.

Table 11: Glazing Response Summary

Specimen	Fracture Status		Comments
	Inboard	Outboard	
3-3	NA	Yes	Lite fractured with full perimeter pullout to the exterior. Two small pieces of glass on the floor 6-in. from the window. Exterior top stop came off but no penetrations.
4-1	NA	Yes	Lite fractured but remained in the opening. 30-in. pullout near the bottom window seal and a 38-in. pullout on the right side. Exterior bottom stop came loose but no penetrations..
4-2	NA	Yes	Unbroken, glass fully retained.
4-3	NA	Yes	Unbroken, glass fully retained.

10.3.2 Frame Response

The frame was undamaged.

11.0 HAZARD RATING

11.1 ISO 16933

11.1.1 Specimens 1 (3 units)- IGU Annealed

The system performed consistent with a “Hazard Rating D”; therefore, the classification code for the glazing is EXV33(D). The exterior lites and interior lites of all the specimens yielded during the air blast pressure loading. The glazing was not retained in the frames for almost all specimens however the glazing was held intact by the film..

11.1.2 Specimens 2 (3 units)- IGU Annealed

The minimum the system performed at was a “Hazard rating C”; therefore, the classification code for the glazing is EXV33(C). The exterior and interior lites of all specimens fractured during air blast pressure loading. The glazing was fully retained in the test frames.

11.1.3 Specimens 3 (3 units)- Single Pane Tempered

The system performed consistent with a “Hazard Rating D”; therefore, the classification code for the glazing is EXV33(D). The lite of all the specimens fractured during the air blast pressure loading. The glazing was not retained in the frames for almost all specimens however the glazing was held intact by the film.

11.1.4 Specimens 4 (3 units)- Single Pane Tempered

The minimum the system performed at was a “Hazard rating C”; therefore, the classification code for the glazing is EXV33(C). The lite of one of the specimens fractured during air blast pressure loading. The glazing was fully retained in the test frames. No breach and no material were lost from the interior surface of the specimen during air blast pressure loading.

12.0 CERTIFICATION AND DISCLAIMER STATEMENT

All tests performed on these test specimens were conducted in accordance with the specifications of the applicable codes, standards and test methods listed below by ATI. ATI does not have, nor does it intend to acquire or will it acquire, a financial interest in any company manufacturing or distributing products tested at ATI. ATI is not owned, operated or controlled by any company manufacturing or distributing products it tests. This report is only intended for the use of the entity named in Section 1.0 of this report. Detailed assembly drawings showing wall thickness of all members, corner construction and hardware applications are on file and have been compared to the test specimens submitted. ATI will service this report for the entire test record retention period. Test records that are retained such as detailed drawings, datasheets, representative samples of test specimens, or other pertinent project documentation will be retained by ATI for the entire test record retention period.

All results obtained apply only to the specimens tested and they do indicate compliance with the performance requirements of the test methods and specifications listed in the following section.

If test specimens contain glazing, no conclusions of any kind regarding the adequacy or inadequacy of the glass in any glazed test specimens can be made. This report does not constitute certification of this product nor an opinion or endorsement by this laboratory. It is the exclusive property of the client so named herein and relates only to the specimens tested. This report may not be reproduced, except in full, without the written approval of ATI.

13.0 APPLICABLE CODES, STANDARDS, AND TEST METHODS

ISO 16933:2007: Glass in building – Explosion-resistant security glazing – Test and classification for arena air-blast loading.

14.0 WITNESSES (ALL OR PARTIAL)

Andy Cost	Lab Manager	Architectural Testing, Inc.
Sierra Conner	Project Engineer	Architectural Testing, Inc.
Jerod Brinkman	Technician	Architectural Testing, Inc.
Michael Sorenson	Technician	Architectural Testing, Inc.
Miguel Detres	Program Manager– Safety & Security Films	Solar Gard®

15.0 APPENDICES

This test report is incomplete if not accompanied by the following Appendices

Appendix A: Test Specimen Drawings..... 13 Pages
 Appendix B: Test Setup..... 2 Pages
 Appendix C: Photographic Record 9 Pages
 Appendix D: SikaSil® SG-20 Technical Product Data 3 Pages
 Revision Log 1 Page

Andy Cost.
 Lab Manager

John H. Waskow, P.E.
 Operations Manager

APPENDIX A:
“Test Specimen Drawings”
12 SHEETS

Test Specimen Drawings- ISO 16933
Solar Gard® Armorcoat® Safety & Security Films

- a. Dual pane frame detail
 - i. Head and Jamb detail

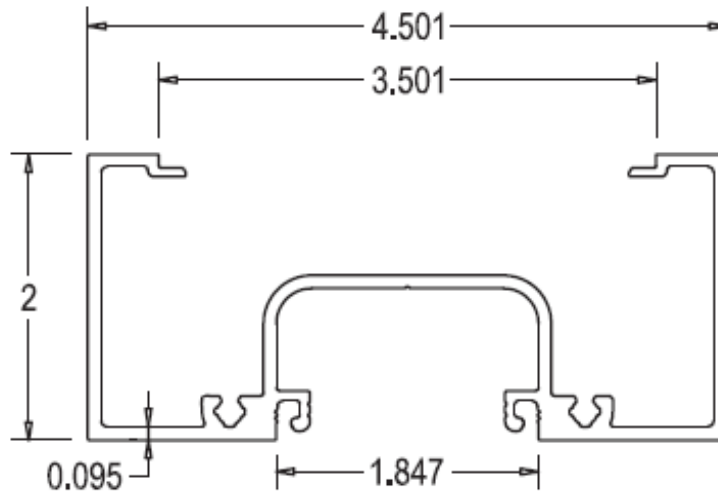

- ii. Sill detail

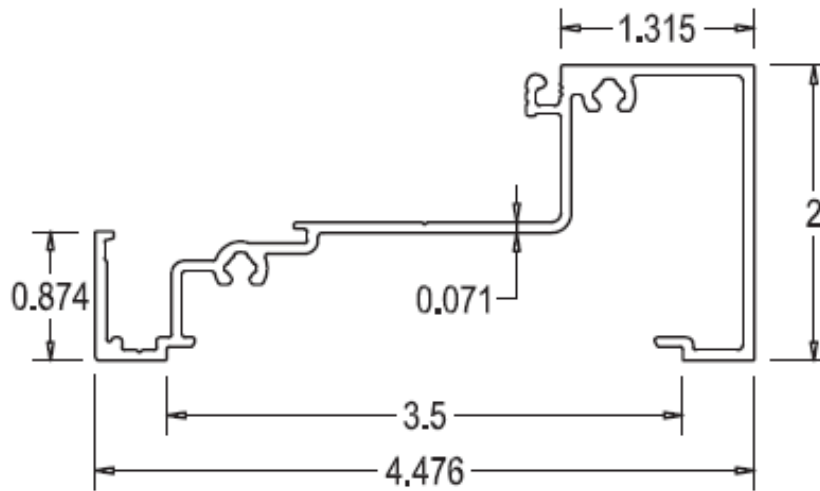

iii. Glazing stop

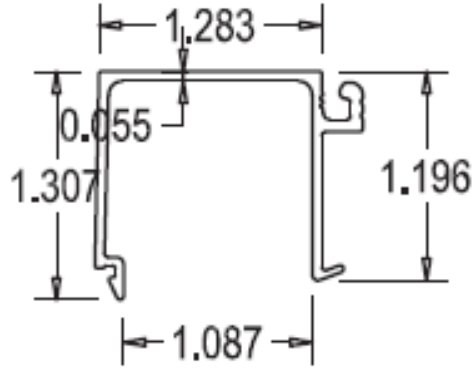

iv. Assembly

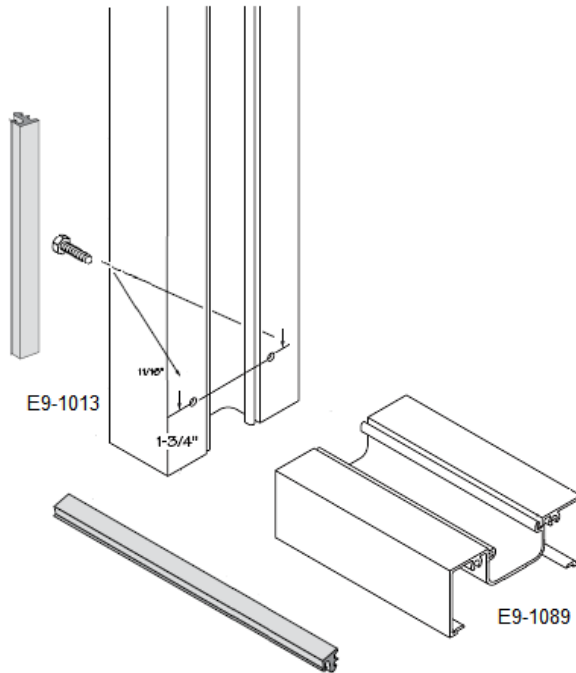

- b. Single pane frame detail
 - i. Head and Jamb detail

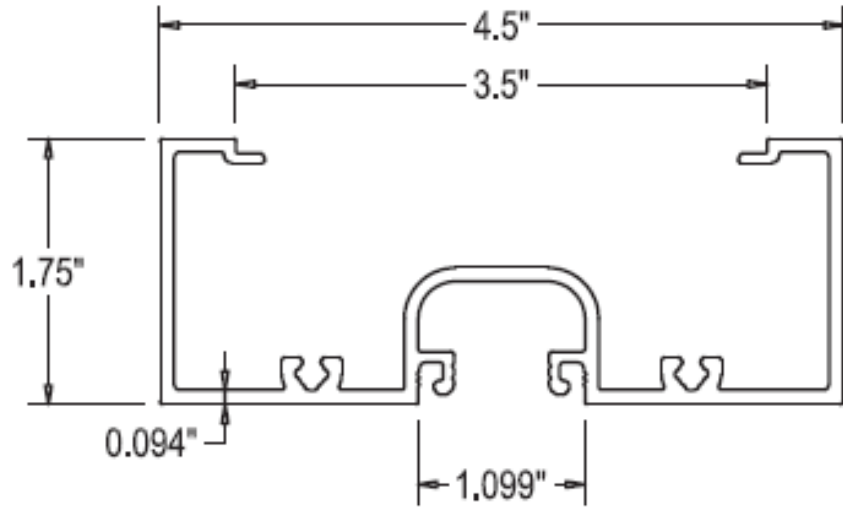

- ii. Sill detail

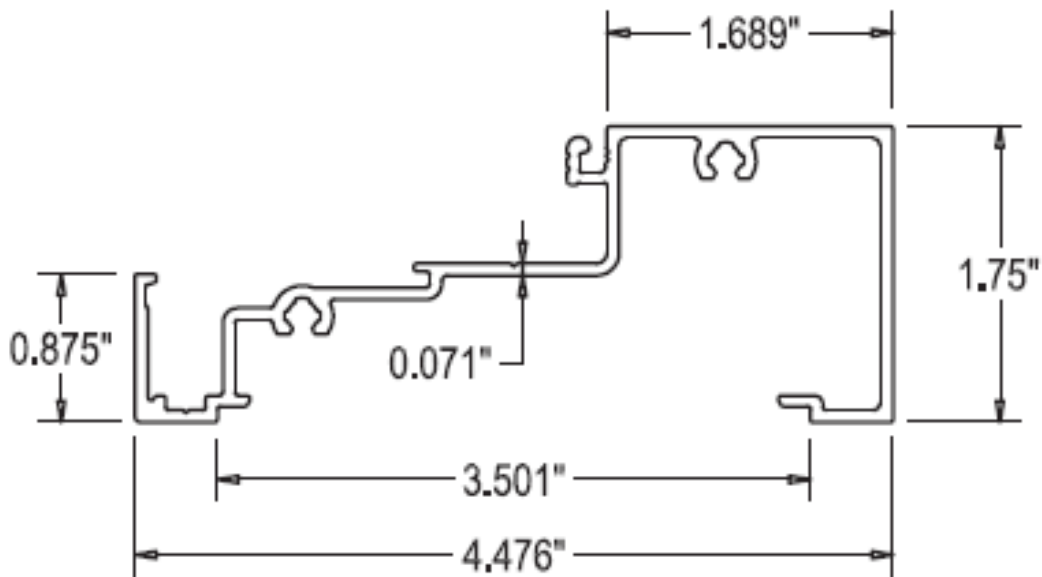

iii. Glazing stop

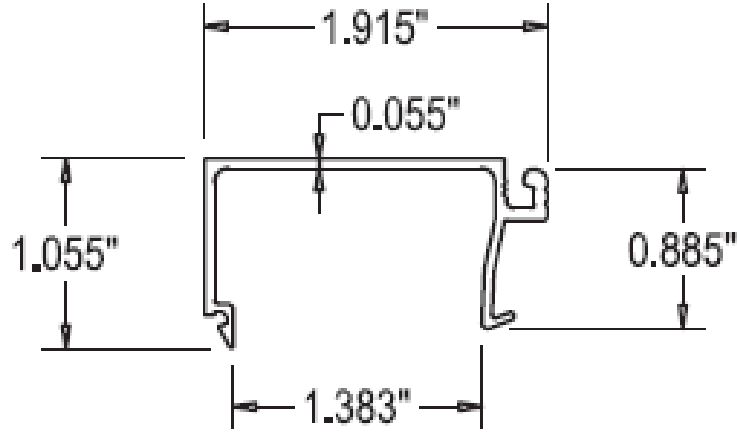

iv. Assembly

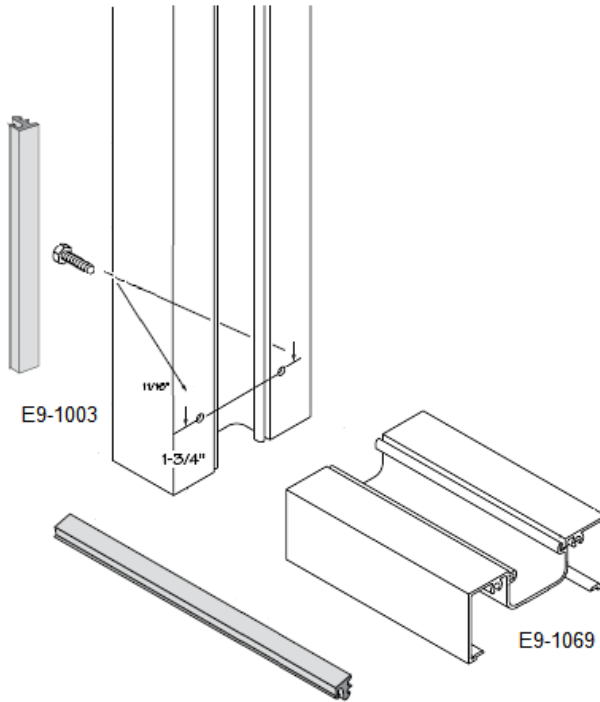

c. Film installation detail

i. Specimen 1 and 3

8mil (200 micron) film on single and insulated glass with EdgPro™ flexible mechanical attachment system

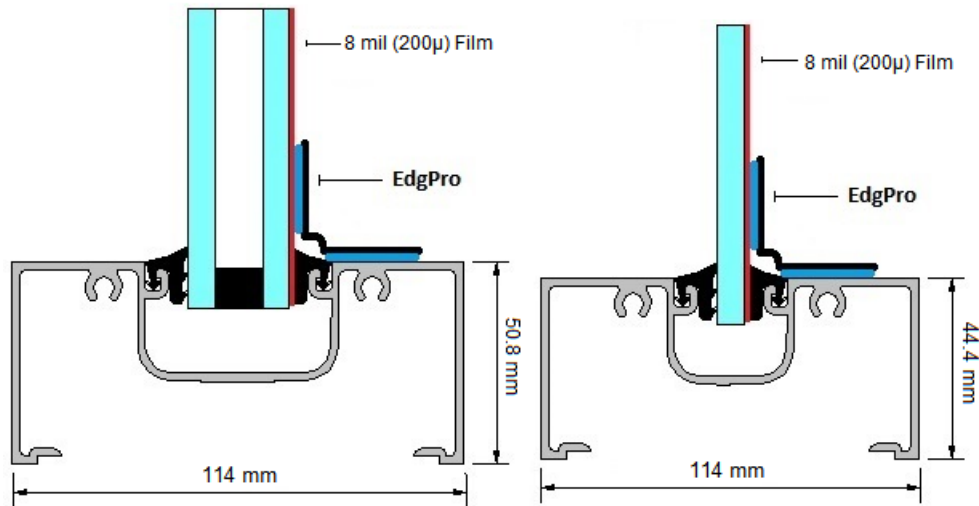

ii. Specimen 2

8mil film on film on Insulated glass with EdgPro™ aluminum mechanical attachment system.

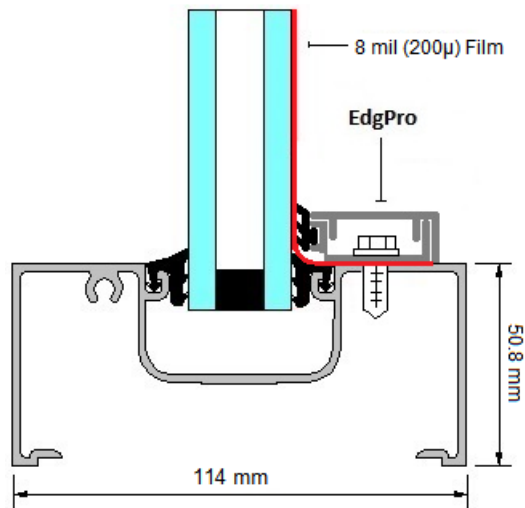



WINDOW FILMS • PHOTOVOLTAICS • CUSTOM COATINGS

iii. Specimen 4

8mil (200 micron) film on single pane glass with wet glaze attachment system

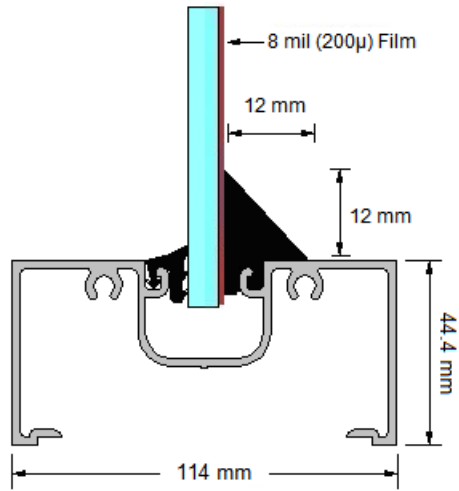

Saint-Gobain Performance Plastics

4540 Viewridge Avenue • San Diego • California 92123 USA • Tel: +1 858 576 0200 • Fax: +1 858 571 3605 • www.solargard.com



WINDOW FILMS • PHOTOVOLTAICS • CUSTOM COATINGS

d. Test Buck & Frame Installation Detail

i. Chamber 1-3

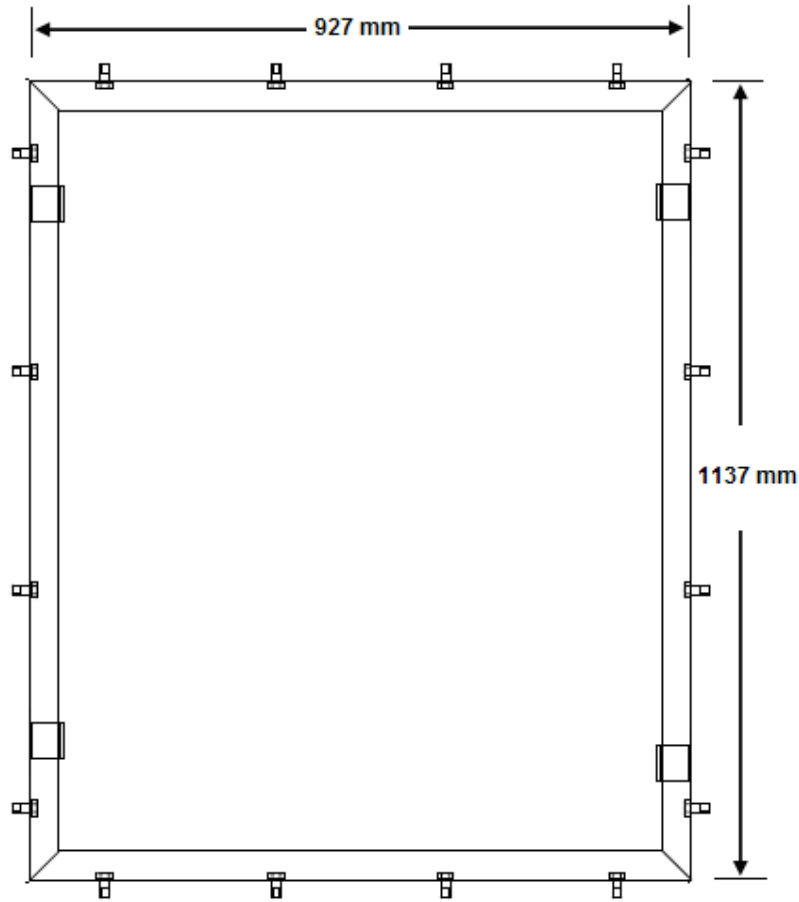

Saint-Gobain Performance Plastics

4540 Viewridge Avenue • San Diego • California 92123 USA • Tel: +1 858 576 0200 • Fax: +1 858 571 3605 • www.solargard.com

e. Chamber 1 -3 Bracket Detail

i. Chamber 1 and 2

Specimen 1 and 2 (1-1, 1-2, 1-3, 2-1, 2-2, 2-3)

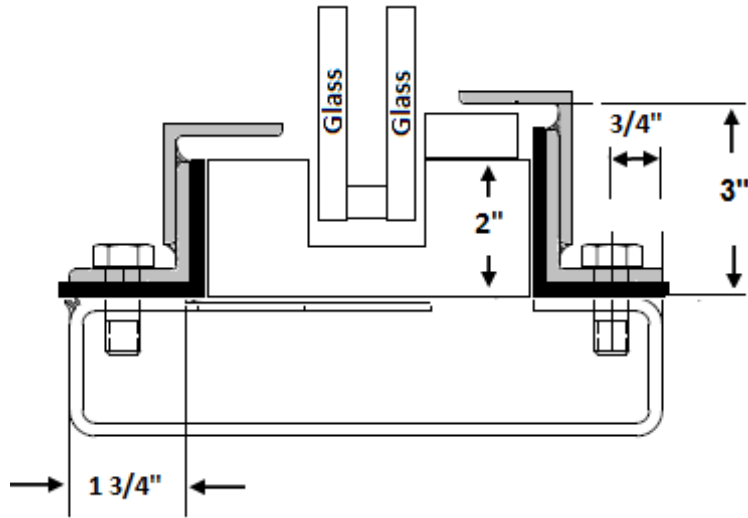

ii. Chamber 1 and 2

Specimen 3 (3-1, 3-2, 3-3)

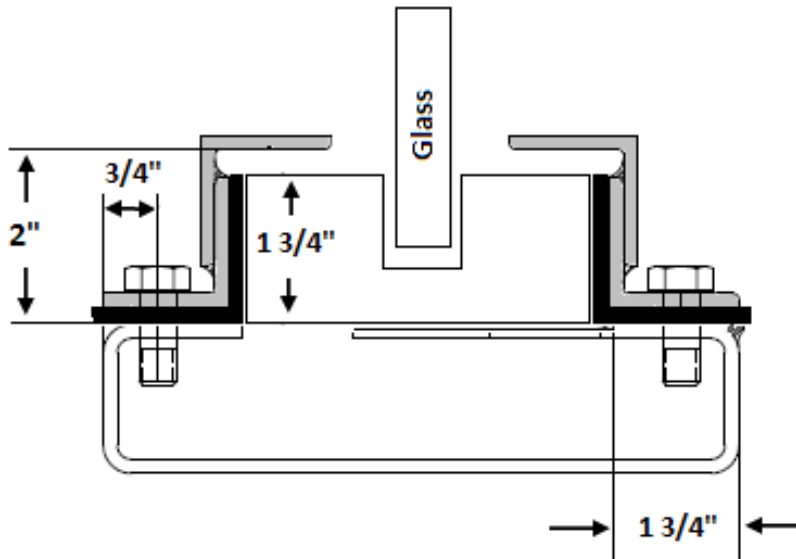

- iii. Chamber 3
Specimen 4 (4-1, 4-2, 4-3)

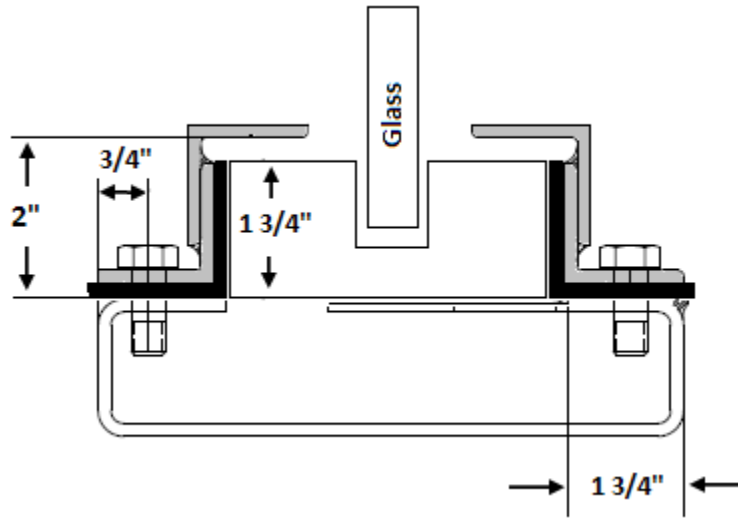



WINDOW FILMS • PHOTOVOLTAICS • CUSTOM COATINGS

f. Chamber drawings

i. Chamber 1

Chamber 1	Specimen	Glazing Type	Film Type	Attachment Type
	1-1	IGU Annealed	Solar Gard Armorcoat 8mil	EdgPro™ Flexible Mechanical
	1-2	IGU Annealed	Solar Gard Armorcoat 8mil	EdgPro™ Flexible Mechanical
	1-3	IGU Annealed	Solar Gard Armorcoat 8mil	EdgPro™ Flexible Mechanical
	2-1	IGU Annealed	Solar Gard Armorcoat 8mil	Four Sided EdgPro™ Aluminum Mechanical

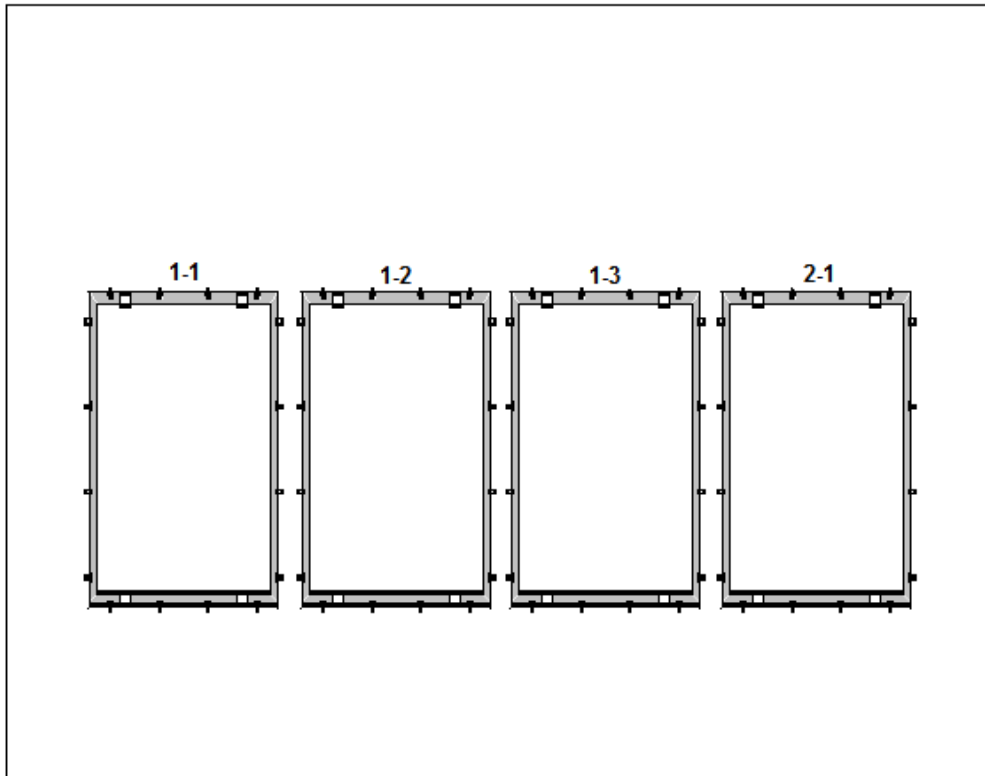

Saint-Gobain Performance Plastics

4540 Viewridge Avenue • San Diego • California 92123 USA • Tel: +1 858 576 0200 • Fax: +1 858 571 3605 • www.solargard.com



WINDOW FILMS • PHOTOVOLTAICS • CUSTOM COATINGS

ii. Chamber 2

	Specimen	Glazing Type	Film Type	Attachment Type
Chamber 2	2-2	IGU Annealed	Solar Gard Armorcoat 8mil	Four Sided EdgPro™ Aluminum Mechanical
	2-3	IGU Annealed	Solar Gard Armorcoat 8mil	Four Sided EdgPro™ Aluminum Mechanical
	3-1	Single Pane Tempered	Solar Gard Armorcoat 8mil	EdgPro™ Flexible Mechanical
	3-2	Single Pane Tempered	Solar Gard Armorcoat 8mil	EdgPro™ Flexible Mechanical

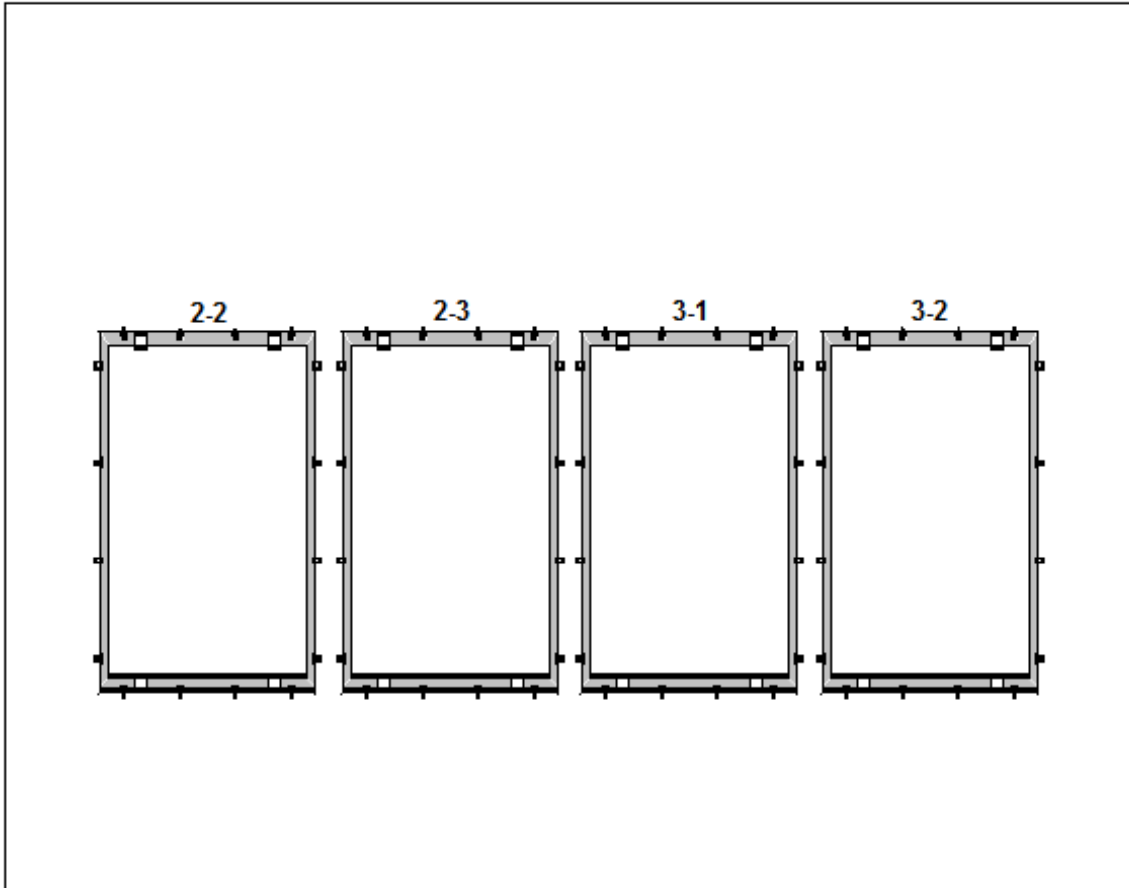

Saint-Gobain Performance Plastics

4540 Viewridge Avenue • San Diego • California 92123 USA • Tel: +1 858 576 0200 • Fax: +1 858 571 3605 • www.solargard.com



WINDOW FILMS • PHOTOVOLTAICS • CUSTOM COATINGS

iii. Chamber 3

	Specimen	Glazing Type	Film Type	Attachment Type
Chamber 3	3-3	Single Pane Tempered	Solar Gard Armorcoat 8mil	EdgPro™ Flexible Mechanical
	4-1	Single Pane Tempered	Solar Gard Armorcoat 8mil	Wet Glaze
	4-2	Single Pane Tempered	Solar Gard Armorcoat 8mil	Wet Glaze
	4-3	Single Pane Tempered	Solar Gard Armorcoat 8mil	Wet Glaze

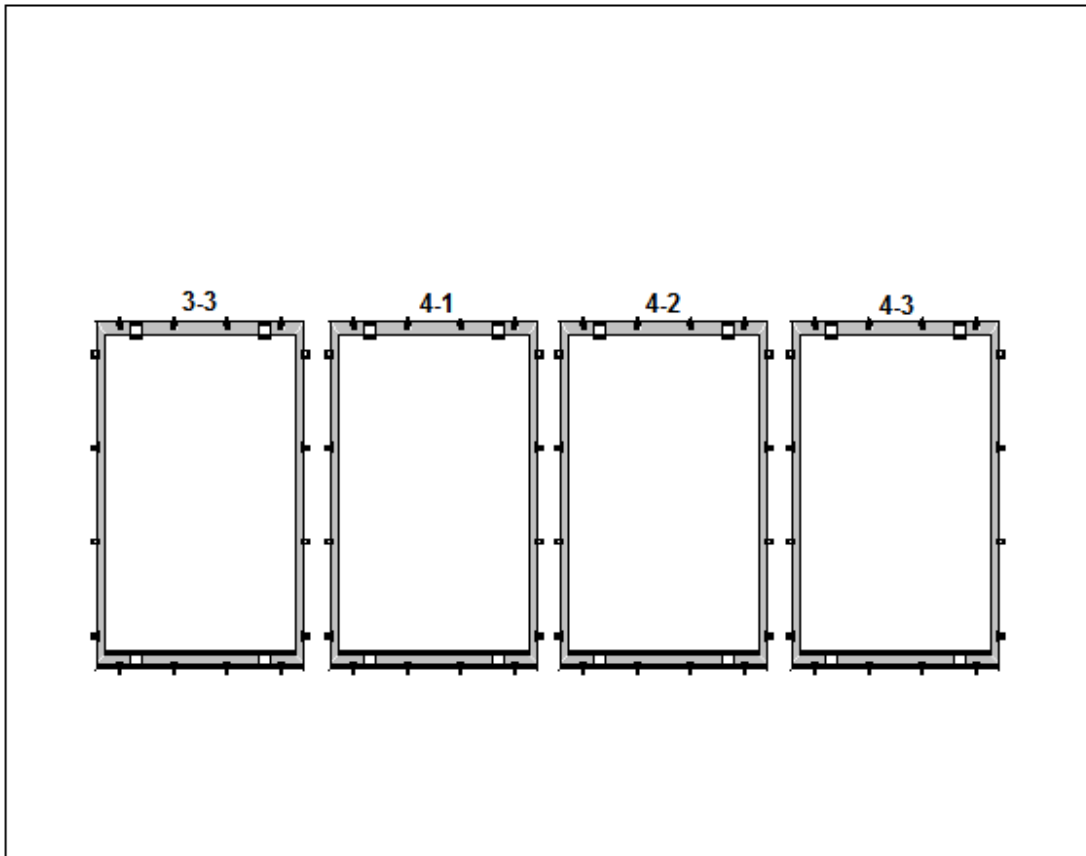

Saint-Gobain Performance Plastics

4540 Viewridge Avenue • San Diego • California 92123 USA • Tel: +1 858 576 0200 • Fax: +1 858 571 3605 • www.solargard.com

**APPENDIX B:
TEST SETUP**



Figure B.1: Range Setup, 124-ft. Standoff



Figure B.2: Clip on Window Frame



Figure B.3: Witness Panel



Figure B.4: Frame Stops Meeting

**APPENDIX C:
PHOTOGRAPHIC RECORD**



Figure C.1: Specimen 1-1
Pre-Blast Condition Exterior



Figure C.2: Specimen 1-1
Pre-Blast Condition Interior View



Figure C.3: Specimen 1-1
Post-Blast Condition



Figure C.4: Specimen 1-1
Glazing Fragments



Figure C.5: Specimen 1-2
Pre-Blast Condition Exterior



Figure C.6: Specimen 1-2
Pre-Blast Condition Interior



Figure C.7: Specimen 1-2
Post-Blast Condition



Figure C.8: Specimen 1-2
Glazing Fragments



Figure C.9: Specimen 1-3
Pre-Blast Condition Exterior



Figure C.10: Specimen 1-3
Pre-Blast Condition Interior



Figure C.11: Specimen 1-3
Post-Blast Condition



Figure C.12: Specimen 1-3
Post-Blast Condition



Figure C.13: Specimen 1-3
Glazing Fragments



Figure C.14: Specimen 2-1
Pre-Blast Condition Exterior



Figure C.15: Specimen 2-1
Pre-Blast Condition Interior



Figure C.16: Specimen 2-1
Post-Blast Condition



Figure C.17: Specimen 2-1



Figure C.18: Specimen 2-1

Post-Blast Condition



Figure C.19: Specimen 2-2
Pre-Blast Condition Exterior

Glazing Fragments



Figure C.20: Specimen 2-2
Pre-Blast Condition Interior



Figure C.21: Specimen 2-2
Post-Blast Condition



Figure C.22: Specimen 2-2
Post-Blast Condition



Figure C.23: Specimen 2-2
Post-Blast Condition



Figure C.24: Specimen 2-3
Pre-Blast Condition Exterior



Figure C.25: Specimen 2-3
Pre-Blast Condition Interior



Figure C.26: Specimen 2-3
Post-Blast Condition



Figure C.27: Specimen 2-3
Post-Blast Condition



Figure C.28: Specimen 3-1
Pre-Blast Condition Exterior



Figure C.29: Specimen 3-1
Pre-Blast Condition Interior



Figure C.30: Specimen 3-1
Post-Blast Condition



Figure C.31: Specimen 3-1
Post-Blast Condition



Figure C.32: Specimen 3-3
Pre-Blast Condition Exterior



Figure C.33: Specimen 3-3
Pre-Blast Condition Interior



Figure C.34: Specimen 3-3
Post-Blast Condition



Figure C.35: Specimen 3-3
Post-Blast Condition



Figure C.36: Specimen 3-3
Post-Blast Condition



Figure C.37: Specimen 3-3
Glazing Fragments



Figure C.38: Specimen 4-1
Pre-Blast Condition Exterior



Figure C.39: Specimen 4-1
Pre-Blast Condition Interior



Figure C.40: Specimen 4-1
Post-Blast Condition



Figure C.41: Specimen 4-2
Pre-Blast Condition Exterior



Figure C.42: Specimen 4-2
Pre-Blast Condition Interior



Figure C.43: Specimen 4-2
Post-Blast Condition



Figure C.44: Specimen 4-3
Pre-Blast Condition Exterior



Figure C.45: Specimen 4-3
Pre-Blast Condition Interior



Figure C.46: Specimen 4-3
Post Blast Condition

APPENDIX D:
SikSil® SG-20 Technical Product Data

SikaSil® SG-20

High strength structural silicone adhesive

Technical Product Data (Typical Values)

Chemical base	1-C silicone
Color	Black, gray, white
Cure mechanism	Moisture
Cure type	Neutral
Density, uncured, Typical (CQP 006-4)	11.4 lb/gal
Non-sag properties	Low Sag
Application temperature	41°F to 104°F (5°C to 40°C)
Skin time ¹	15 min
Tack free time ¹	180 min
Curing speed	(see diagram 1)
Shore A-hardness, (ASTM D2240)	39
Tensile strength, (ASTM D 412)	320 psi
Elongation at break, (ASTM D 412)	450%
Tear propagation resistance, (ASTM D624)	40 pli
Movement accommodation factor, (ISO 11 600)	+/- 25%
Service temperature	-40°F-302°F (-40°C-150°C)
Shelf life (storage below 77°F (25°C))	9 months

¹ 73°F (23°C) / 50% r.h. CQP=Corporate Quality Procedure

Description

SikaSil® SG-20 is a neutral curing silicone adhesive which combines mechanical strength with high elongation. It has excellent adhesion to a wide range of substrates. SikaSil® SG-20 is manufactured in accordance with ISO 9001/14001 quality assurance system and the responsible care program.

Product Benefits

- Outstanding UV and weathering resistance
- Excellent bond to glass, metals, coated metals, plastics and wood
- Fire rated (EN 11925-2/DIN 4102-B1)
- Meets requirements of ASTM C1184
- Neutral cure

Areas of Application

SikaSil® SG-20 can be used for structural sealant glazing or as a residential window backbedding / glazing adhesive, or for bonding solar modules and other high-demanding industrial applications. Tests with original substrates and conditions must be performed to ensure adhesion and material compatibility.

Industry



Cure Mechanism

SikaSil® SG-20 cures by reaction with atmospheric moisture. The curing speed depends on the relative humidity and temperature. Heating above 122°F (50°C) is not advisable as it may lead to bubble formation. At low temperatures the water content of the air is lower and the curing reaction proceeds more slowly (see diagram below).

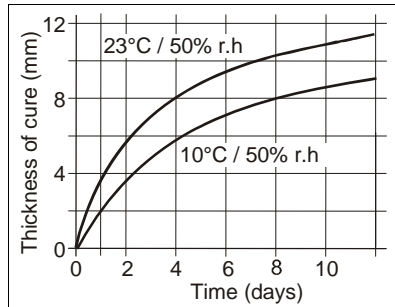

Diagram 1: Curing speed SikaSil®-TS Plus

Chemical Resistance

SikaSil® SG-20 is resistant to UV radiation, fresh water, seawater and proprietary aqueous cleaning agents; temporarily resistant to fuels, mineral oils, vegetable and animal fats and oils; not resistant to organic acids, concentrated mineral acids, caustic solutions and solvents. The above information is offered for general guidance only. Advice on specific applications will be given on request. Contact the Technical Service Department of Sika Industry at tsmh@sika-corp.com.

Method of Application

Surface preparation

Surfaces must be clean, dry and free from all traces of oil, grease, dust, rust, and other contaminants. Advice on specific applications and surface pretreatment methods is available from the Technical Service Department of Sika Industry at tsmh@sika-corp.com.

Application

After suitable joint and substrate preparation, SikaSil® SG-20 is

gunned into place. Joints must be properly dimensioned as changes are no longer possible after construction. Basis for calculation of the necessary joint dimensions are the technical values of the adhesive and the adjacent building materials, the exposure of the building elements, their construction and size as well as external loads. Joints deeper than 0.6in (15mm) should be avoided. For more information, please contact the Technical Service Department of Sika Industry at tsmh@sika-corp.com.

Tooling and finishing

Tooling and finishing of SikaSil® SG-20 must be carried out within its skin time. When tooling freshly applied SikaSil® SG-20 press the adhesive into the joint to get a good wetting of the bonding surface. No tooling agents should be used. Dry tool only.

Removal

Uncured SikaSil® SG-20 may be removed from tools and equipment with Sika® Remover-208 or another suitable solvent. Strictly follow solvent manufacturer's instructions for use and warnings. Once cured, the material can only be removed mechanically. Hands and exposed skin should be washed immediately after use. Do not use solvents on skin!

Overpainting

SikaSil® SG-20 cannot be overpainted.

Limitations

All SikaSil® silicone sealants and adhesives are compatible with each other. All other sealants have to be approved by Sika before using them in combination with SikaSil® SG-20. Where two or more different reactive sealants are used, allow the first to cure completely before applying the next.

SikaSil® SG-20 may only be used in structural glazing or window bonding applications by experienced professionals. **It is the end user's**

responsibility to determine the suitability of the product for their windows and conduct appropriate testing for verification.

The compatibility of gaskets, backer rods, setting blocks and other accessory materials with SikaSil® SG-20 must be tested in advance.

The above information is offered for general guidance only. Advice on specific applications will be given on request.

Cautions

WARNING: IRRITANT, SENSITIZER. Contains Polyisocyanate Pre-polymer (Mixture). Causes eye irritation. May cause skin/respiratory irritation. May cause skin and/or respiratory sensitization after prolonged or repeated contact. May be harmful if swallowed. Use only in well ventilated areas. **Deliberate misuse by inhalation of vapors may be harmful or fatal. Strictly follow all usage, handling and storage instructions. DO NOT USE IN DRINKING WATER SYSTEMS OR SWIMMING POOLS.**

Handling, Storage and Cleanup

Handling and Storage

Avoid direct contact. Remove contact lenses prior to use. Wear personal protective equipment (chemical resistant goggles/gloves/clothing) to prevent contact with skin and eyes. Use only in well ventilated areas. Open doors and windows during use. Use a properly fitted NIOSH respirator if ventilation is poor. Wash thoroughly with soap and water after use and before reinserting lenses. Remove contaminated clothing and launder before reuse. Store in unopened containers in dry conditions.

Cleanup

Use personal protective equipment (chemical resistant goggles/ gloves/ clothing). Without direct contact, remove spilled or excess product and place in a suitable sealed container. Dispose of excess product and container in accordance

Further information available at:
www.sikaindustry.com

Sika Corporation
Industry Division
30800 Stephenson Highway
Madison Heights, Mi 48071
USA
Tel. 248 577 0020
Fax 248 577 0810



with applicable environmental regulations.

HMIS

Health	*1
Flammability	1
Reactivity	0
Personal Protection	C

First Aid Measures

Eyes - Hold eyelids apart and flush thoroughly with water for 15 minutes. **Skin** - Remove contaminated clothing. Wash skin thoroughly for 15 minutes with soap and water. **Inhalation** - Remove to fresh air. **Ingestion** - Do not induce vomiting. Dilute with water. Contact physician. **In all cases, contact a physician immediately if symptoms persist.**

Further Information

Copies of the following publications are available at www.sikaindustry.com.

- Material Safety Data Sheets
- Product Data Sheets
- General guidelines for bonding and sealing with Sika products

Packaging Information

Cartridge	10.5 oz
Unipac	20 oz
Pail	4.8 gal
Drum	50 gal

Important

For further information and advice regarding transportation, handling, storage and disposal of chemical products, users should refer to the actual Material Safety Data Sheets containing physical, ecological, toxicological and other safety related data. It is highly recommended to read the actual Material Safety Data Sheet before using the product.

**KEEP OUT OF REACH OF CHILDREN
NOT FOR INTERNAL CONSUMPTION
FOR INDUSTRIAL USE ONLY
KEEP CONTAINER TIGHTLY CLOSED**

**In case of emergency, call
CHEMTREC at 1-800-424-9300,
International 703-527-3887**

**For more information, consult Material
Safety Data Sheet and Product Data
Sheets available through
www.sikaindustry.com**

Value Basis

All technical data stated on this Product Data Sheet are based on the results of laboratory tests only. Actual measured data in the field may vary due to site specific conditions which are not known to Sika and beyond our control.

Limited Material Warranty

SIKA warrants this product for one year from date of installation to be free from manufacturing defects and to meet the technical properties on the current Product Data Sheet if used as directed within shelf life. User determines suitability of product for intended use and assumes all risks. Buyer's sole remedy shall be limited to the purchase price or replacement of product exclusive of labor or cost of labor. **NO OTHER WARRANTIES IMPLIED OR EXPRESS SHALL APPLY INCLUDING ANY WARRANTY OF MERCHANTABILITY OR FITNESS FOR A PARTICULAR PURPOSE. SIKA SHALL NOT BE LIABLE UNDER ANY LEGAL THEORY FOR SPECIAL OR CONSEQUENTIAL DAMAGES. SIKA SHALL NOT BE RESPONSIBLE FOR THE USE OF THIS PRODUCT IN A MANNER TO INFRINGE ON ANY PATENT OR ANY OTHER INTELLECTUAL PROPERTY RIGHTS HELD BY OTHERS.**

Legal Notes/Disclaimer

All information provided by Sika Corporation ("Sika") concerning Sika products, including but not limited to, any recommendations and advice relating to the application and use of Sika products, is given in good faith based on Sika's current experience

and knowledge of its products when properly stored, handled and applied under normal conditions in accordance with Sika's instructions. In practice, the differences in materials, substrates, storage and handling conditions, actual site conditions and other factors outside of Sika's control are such that Sika assumes no liability for the provision of such information, advice, recommendations or instructions related to its products, nor shall any legal relationship be created by or arise from the provision of such information, advice, recommendations or instructions related to its products. The user of the Sika product(s) must test the product(s) for suitability for the intended application and purpose before proceeding with the full application of the product(s).

Sika reserves the right to change the properties of its products without notice. All sales of Sika product(s) are subject to its current terms and conditions of sale which are available at www.sikacorp.com or by calling 201-933-8800.

Prior to each use of any Sika product, the user must always read and follow the warnings and instructions on the product's most current Product Data Sheet, product label and Material Safety Data Sheet which are available at www.sikaindustry.com. Nothing contained in any Sika materials relieves the user of the obligation to read and follow the warnings and instruction for each Sika product as set forth in the current Product Data Sheet, product label and Material Safety Data Sheet prior to product use.

Further information available at:
www.sikaindustry.com

Sika Corporation
Industry Division
30800 Stephenson Highway
Madison Heights, Mi 48071
USA
Tel. 248 577 0020
Fax 248 577 0810



Revision Log

Rev. #	Date	Page(s)	Section #	Revision(s)
0	05/26/16	N/A	N/A	Original Report Issued.